



*fresh thinking!*TM

Brand Guidelines Update - Document B

Effective December 2011

Authorised by Joanna Stephenson, VP Marketing & Innovation

These brand guidelines have been developed for stakeholders requiring brand use information, to simplify, harmonise, protect and control the LINPAC Packaging name, brands and identity. THIS DOCUMENT MAY BE USED EXTERNALLY.

For internal users requiring brand use information, please refer to Document A - LINPAC Packaging Brand Guidelines - For Internal Use.

Contents

The Company Logotype	3
How to use the logotype	4
The Company Logotype	4
The Company Logotype	5
Stationery	6
General Folders and Brochures	7
Sub-Brands Management	8
Sub-Brands Management	9
Use of Trademarks - General Principles	10
Introduction	10
Use only for Goods & Services	10
Acknowledgements	10
Use of the LINPAC trademarks	10
Trade names	11
New Trade Marks	11
LINPAC Packaging Trademarks Use	11
Use of the LINPAC trademarks	11
Protecting the LINPAC Logotype	12
Typography	12
Use of the LINPAC trademarks	12
Uniforms	13
Signage	14
Recycling Symbols	15
Contact Details	16

For an questions relating to the use of the LINPAC Packaging name, brand or identity please contact info@linpacpackaging.com.

LINPAC Packaging Limited
Wakefield Road
Pontefract
West Yorkshire
WF7 5DE
Tel: +44 (0)1977 692111

LINPAC Packaging is a trademark and is only to be used with express permission. These brand guidelines are the property of LINPAC Packaging and must be returned on request.



The LINPAC Packaging logotype has been developed for use across all media applications.

LINPAC Packaging is part of the LINPAC Group and the current logo will be maintained with the addition of the Fresh Thinking tag line until further notice.

The logotype must always appear as shown, and must never be redrawn or regenerated using standard typefaces. To maintain a consistent and credible corporate image, the accompanying guidelines must be adhered to.



How to use the logotype

Colour Specification

The LINPAC Packaging corporate colours are PMS Red 485, PMS Green 369, Pantone Blue 2925 and Black. Always refer to accurate colour swatches as a final check and balance accordingly.

Colour Logo



Black & White Logo



Green Logo



Blue Logo



Reversed out of a solid colour

Where possible the logotype should be used on a white background but where this is not possible it should be used on a solid background as shown.



LINPAC Packaging logo on red block background

Exclusion zone around the logotype



To protect the logotype from other material encroaching on it, an exclusion zone around the logo is specified. This should be adhered to to preserve the specific impact of the logo. The exclusion zone is 20mm in all directions.

Ideal & Minimum Sizes

Where possible the logotype should be used in a 20mm or 35mm format as shown below and should not be used at less than 10mm size.



20mm Logo

35mm logo

10mm logo with red cross through it

Use of Logotype rules

1. Do not distort, stretch or manipulate the logotype in anyway
2. Do not add any words or graphics to the new fresh thinking logotype
3. Do not place the logotype in a visually competitive background
4. Do not use the logotype with another graphic device
5. Do not change the typeface in the logotype
6. Do not use the logotype as a word in a sentence, phrase or name
7. Do not recolour or use the logotype as a pattern
8. Do not use the logotype at low resolution or download it from a website
9. Do not use the logotype with a border
10. Do not self create electronic letterheads that use the logotype
11. Do not paste the logotype into email or autosignature - a formal email signature is provided by IT for your use.

Stationery for all LINPAC Packaging companies has not changed from the previous 2009 Identity guidelines issued and no LINPAC Packaging stationery updates are required at the current time.

Stationery for all LINPAC Packaging companies must be based on the letterhead, compliment slip and business card shown . All stationery must be approved by Head Office.

Endorsements and accreditations

The following examples show how secondary graphic elements may be applied

Paper specifications

Letterhead, compliment slips and continuations - Conqueror Smooth Wove, diamond white 100g.

Business cards

Conqueror Smooth CX22 diamond white 350g.

Envelopes

Conqueror Smooth Wove, diamond white.

A4 Letterhead

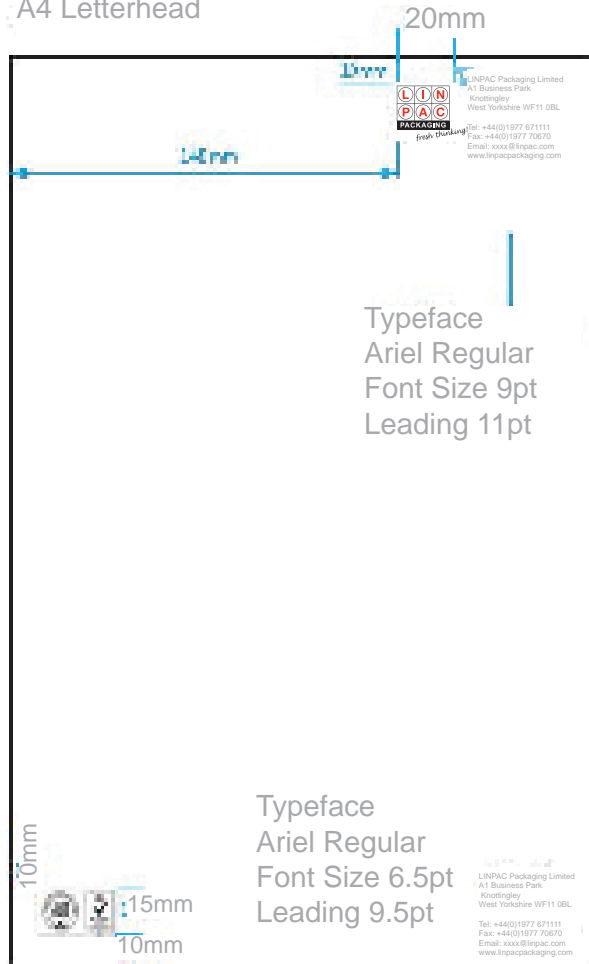

Business card 85 x 55mm

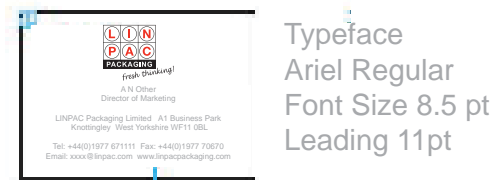

Envelopes

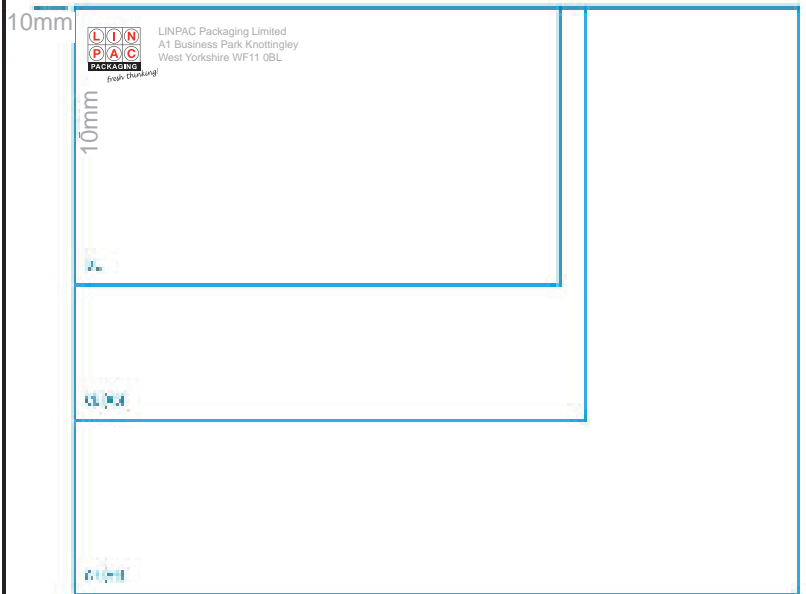

Compliment Slip

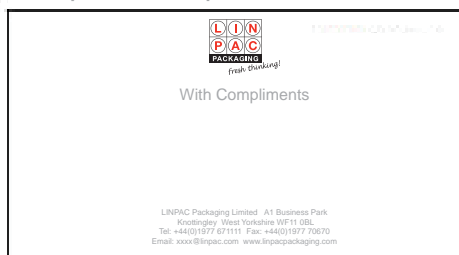

Continuation page

Only the LINPAC Packaging logo should appear. Its position must be 10mm from top and left of the page with the logo 15mm long

Please note all guidelines are consistent with the Identity Guidelines of 2009 with exception of the font type and the addition of the fresh thinking tag line.

General Folders

Folders should be plain white, glossy paper format.

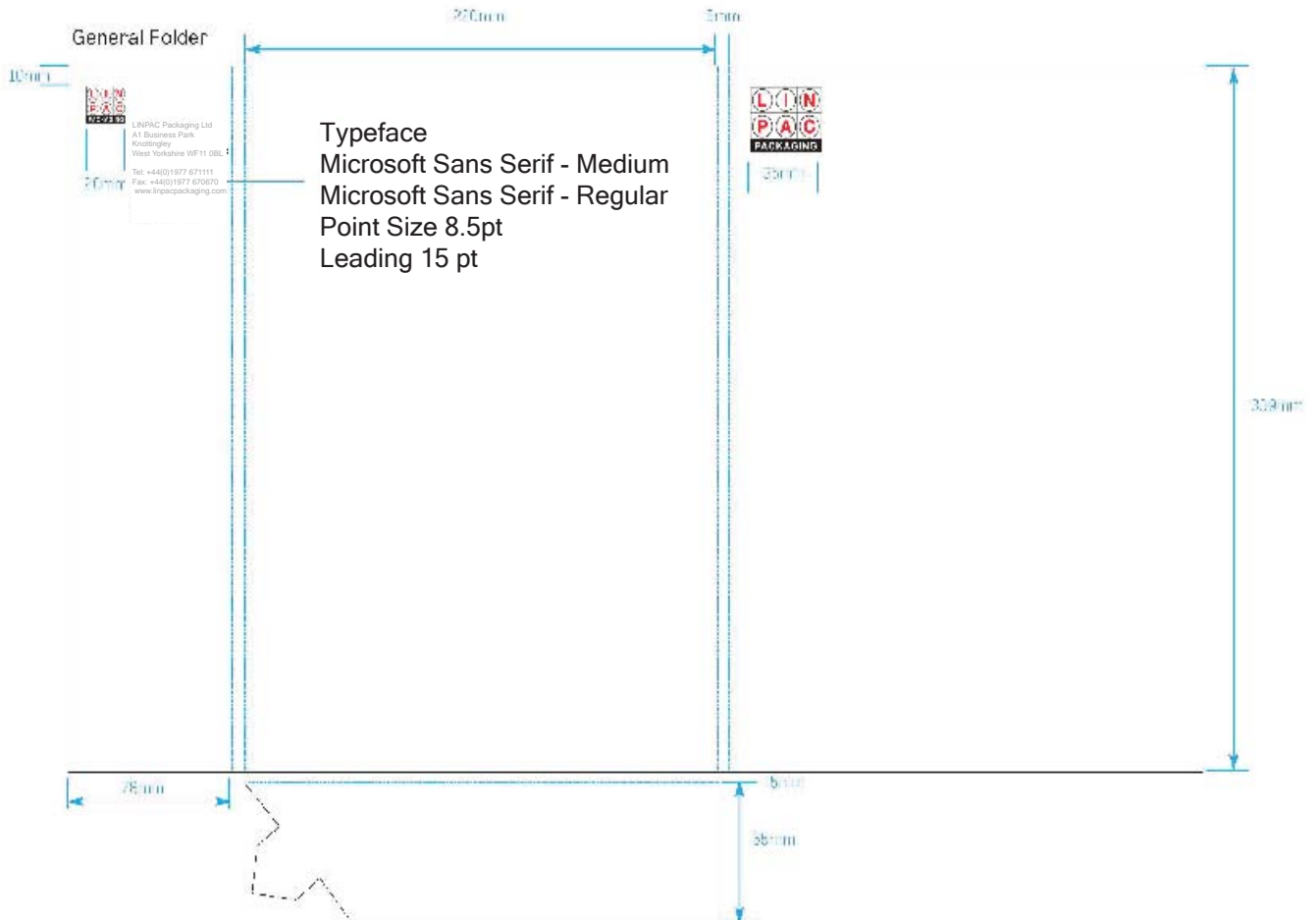

The product names shown below have been specifically designed and must never be redrawn or recreated from the standard typefaces. These brand logos should only be used when the LINPAC Packaging logo already appears in the same area e.g. product literature front covers.

All new product launches are subject to stringent commercialisation protocols and must be approved by the Vice President of Marketing & Innovation. Not all new products will have brand logos developed. The aim of the fresh thinking strategy is to simplify and harmonise our approach to branding. However, the following sub-brands will be maintained.

Please note: In certain circumstances when scale allows, the LINPAC Packaging logo can be used with the sub brand as indicated below. Please ensure that the scale does not go below the minimum size.

LINPAC Packaging logo plus a sub brand graphic example



Despite the colour and font change to the LINPAC Packaging brands, no new packaging, labels, stationery, workclothes etc should be changed until new materials are required, to minimise the cost to the company. Only at the point of product changeover or launch will the new fresh thinking look be integrated into purchased products as listed above.

LINtray®

LINstar®

LINdri®

LINfresh®

fresh PP®

fresh HB®

rfresh® PP®

rfresh® MB®

rfresh® HB®

rfresh® Elite®

HOTpac®

Trimplate®

Chippy®

Frya®

LINbox

MaxiLIN®

LINspenser®

ComboPAC®

OpenPAC®

Press & Cut®

LINroll

PerfoLIN®

MagicLIN®

LINcook®

OxoLIN®

LINtop®

LINtop® PP

LINtop® PP HB

LINtop® PE

LINtop® PE HB

LINtop® PET HB

LINtop® Alu

LINtop® Vac

LINtop® Vac HB

LINtop® Vac S

LINtherm® Vac

LINtherm® Vac HB

LINform®

Polydal

LINlam

LINwrap®

LINalta®

Zenium®

OptiLIN®

LINfirst

MultiLIN®

LINwrap® Premium

LINwrap® Cast

LINwrap® VLMF

LINwrap® Newstar

LINwrap® LPE

LINwrap® HPE

etc

The only exception to this will be the current New Leaf logo which we will continue to use until further notice



Use of Trademarks - General Principles

Introduction

The LINPAC Packaging trademarks are some of our most valuable assets. Many of the company's trademarks are recognised internally as representing the highest standards of product quality. It is therefore vital that the company's trademarks are protected from any imitators and that they are not misused.

This section sets out the rules and guidelines for the proper use and maintenance of all the company's trademarks. It covers such issues as:

- Trademark presentation
- The relationship between the LINPAC Packaging name and the company's product marks
- Use of trademarks in promotional material
- Use of trademarks by third parties (licensees, suppliers etc)

By following these guidelines, LINPAC Packaging trademarks will remain strong, consistent and protected.

What is a trademark?

A trademark is a sign capable of being represented graphically and may be a word, phrase, symbol, letters, numerals or the shape of goods or their packaging. A trademark registration gives its owner the right to sue for infringement anyone who uses a confusingly similar mark on any of the goods or services for which the mark is registered (often for confusingly similar goods and services too).

However, the rights acquired by registration and the rights that go with it, can be lost if a mark is not used correctly as a trademark. Some words now in everyday use started off their life as trade marks for example gramophone, escalator and tabloid and others, while still registered, are frequently thought of by the public as common names such as Biro, Thermos and Cellophane.

The LINPAC Packaging and LINPAC Group trademarks should always be used in the manner to which they were registered. If they are not so used, then LINPAC might not be able to assert its registration rights against a third party. For example, on occasion, a trademark may be registered in some countries with a hyphen and in some countries without. In such cases the trademark should always appear with the hyphen in those countries in which it is so registered. Similarly a trademark may be registered in some countries with a different ending to facilitate pronunciation. For example in Romance speaking countries the IN ending is often altered to INE. In such cases the trademark must always appear in the manner in which it has been registered.

In German, it is common grammatical practice for nouns and adjectives to be combined to form composite new words. Trademarks should never be used in this fashion, again because a mark must be used as it is registered.

Service Marks: It is possible to register marks for services in most major industrial countries as well as for goods.

Use only for Goods & Services

A trademark must be used to describe goods or services not something tangible such as a process or a system and preferably not to describe a business or the department or plant where the product is marketed or made.

Acknowledgements

LINPAC trademarks should only be used on goods made by LINPAC or, if the product is made under license, by one of the LINPAC authorised licensees. An appropriate acknowledgement of ownership should appear on a brochure, packaging or label.



Marks belonging to third parties

From time to time it may be necessary to refer in a piece of literature to trademarks owned by third parties. In such cases the owner of the trademark should be identified.

Trademarks are infinite

Remember that trademarks live forever, so never use them in a gimmicky way just to satisfy a short term need for additional publicity. All trademark development and use should be approved by the Vice President of Marketing.

Cancellation for non-use

In most countries, trademark registrations are vulnerable to cancellation if they have not been used after a period of time, usually 5 years but sometimes sooner.

Trade names

A trade mark is not the same thing as a trade name. Legally, a trade name is the business name or trading style of a company. The two terms are frequently interchanged but this is incorrect and should be avoided.

New Trade Marks

No new trademark may be adopted without clearance searches and specific approval. All enquiries concerning trademarks should be addressed to the Vice President of Marketing at LINPAC Packaging Headquarters, Knottingley.

Always Insert Trademark Acknowledgement

If a trademark is used in the text of a document, in a powerpoint presentation or external communication, the trademark should carry an acknowledgement somewhere in the document (usually at the bottom of a slide or end of the document). For example:

LINfresh®

“LINfresh® is a trademark of LINPAC Packaging”

LINPAC Packaging Trademarks Use

1. Always use an adjective

A trademark is an adjective. It is not a noun and it is not a verb. It should always be used in print as an adjective qualifying a noun or noun phrase. The noun or noun phrase which the trademark adjective must qualify is of course the generic name for the product.

Example of incorrect use

This tray has been **LINFreshed....**

Example of correct use

This is a **LINfresh tray...**

This correct grammatical treatment is frequently overlooked and is bad trademark practice. More importantly it can damage the mark and brand itself.



2. Do not use plurals or possessives

A trademark being an adjective must not appear in the plural or possessive sense.

Example of incorrect use

All the LINPACs are for better food hygiene
LINPAC's unique properties....
LINfresh's unique properties

Example of correct use

LINPAC improves food hygiene
LINPAC has unique properties
LINFRESH® has unique properties

Protecting the LINPAC Logotype

Shown below are examples of LINPAC Packaging logotypes. This style of presentation must be used when trademarks appear as logotypes e.g. main headers on packaging, product labels etc. There are specific rules regarding the use of our logotypes which are set out below:

1. The LINPAC logotype should never be used in the middle of body copy - it should always be used in the text format (font) with the LINPAC always in upper case.
2. Whenever it is used as a logotype it must have a "clear zone" around it to avoid any images or text encroaching upon it and to ensure that it is always presented with clarity.

Typography

The following fonts should be used at all times when producing publicity materials.

Headline & Text Typefaces

MS Sans Serif 8.5pt on 9.5pt (Bold, Regular, Black)
ABCDEFGHIJKLMNOPQRSTUVWXYZ
abcdefghijklmnopqrstuvwxyz

ABCDEFGHIJKLMNOPQRSTUVWXYZ
abcdefghijklmnopqrstuvwxyz

Logos

Hypatia Sans Pro 24pt on 28.8 pt (Bold, Regular Black)

ABCDEFGHIJKLMNOPQRSTUVWXYZ
abcdefghijklmnopqrstuvwxyz

No update of uniforms from the Brand Guidelines of 2009 is planned.



Badging detail



T shirt

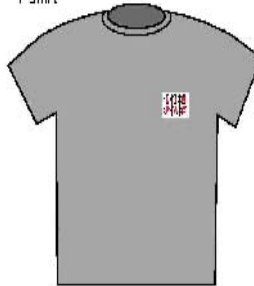

Polo shirt



Lightweight jacket & trousers

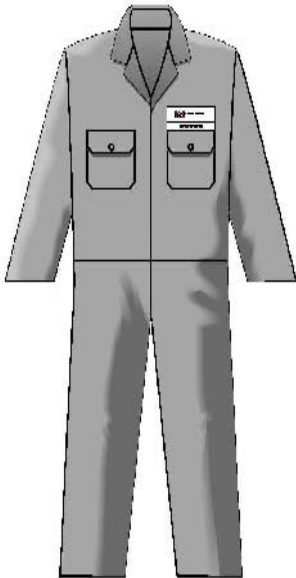

Bib overalls

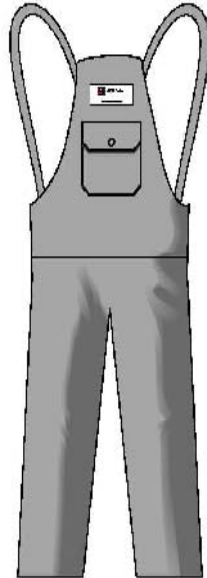

Pocket detail



Jumper



Shirt



Winter weight jacket



Please refer to the Health & Safety Manager for guidance on all signage. Materials should always be durable, practical and of good quality. Where relevant all signage is to be translated to the spoken language (s) used by the workforce at each site.

For overall site name and branding (non H&S) signage, please provide copies of plans to the Vice President of Marketing for alignment to corporate standards where new signage is required.

Health



Warning



Prohibition



Warning



Fire



An industry backed voluntary system, developed by the Society of the Plastics Industry (SPI), is in place for plastic packaging to identify the material type. The purpose of coding is to assist recyclers in sorting plastic containers by resin composition. The systems intended for voluntary use by packaging producers, to be moulded or otherwise imprinted onto the bottom surface of the plastic container. This container coding system has been created and is recommended to the industry to provide a consistent national identification mark that meets the needs of the recycling industry, as defined by the recyclers and collectors themselves.

The system is designed to be the most convenient for the people who will sort the packaging and is intended to avoid a complicated system which would require extensive worker training and possibly lead to confusion or mis-sorting. Given today's national marketplace, it is crucial that the coding system is standardised nationally. The use of different code systems by various companies or states could significantly disrupt the flow of commerce.

(AIM) recommends the use of the American SPI Plastics Coding System for Packaging (these may vary slightly from those shown below).

Locate symbol to not interfere with the full circular path of the decorating detent. Also, interfere as little as possible with the 'clear area' customers may specify for product coding or other purposes.

- 01 PFT Polyethylene terephthalate
PET
- 02 PDI High density polyethylene
HDPE
- 03 PVC Vinyl
PVC
- 04 PELD Low density polyethylene
LDPE
- 05 Polypropylene
PP
- 06 Polystyrene
PS
- 07 All other resins and layered multi-material
OTHER

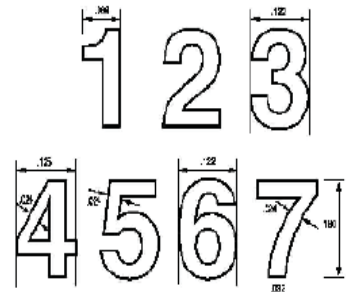
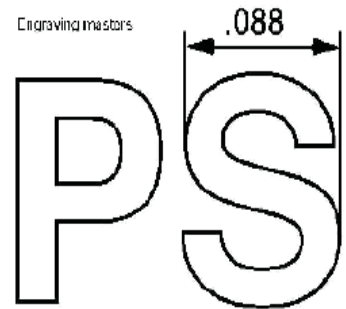
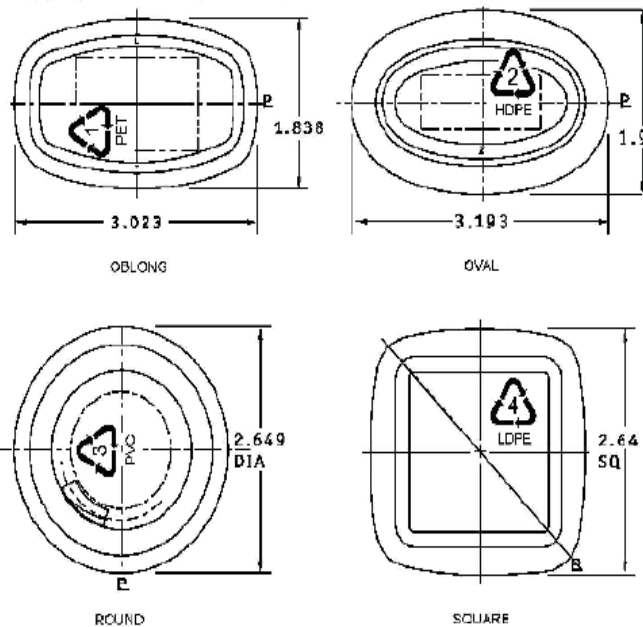



For any questions relating to the use of the LINPAC Packaging name, brand or identity please contact:

info@linpacpackaging.com.

LINPAC Packaging Limited
Wakefield Road
Pontefract
West Yorkshire
WF7 5DE
Tel: +44 (0)1977 692111